

TTH731-ATS / SELF CONTAINED EMERGENCY LUMINARIES

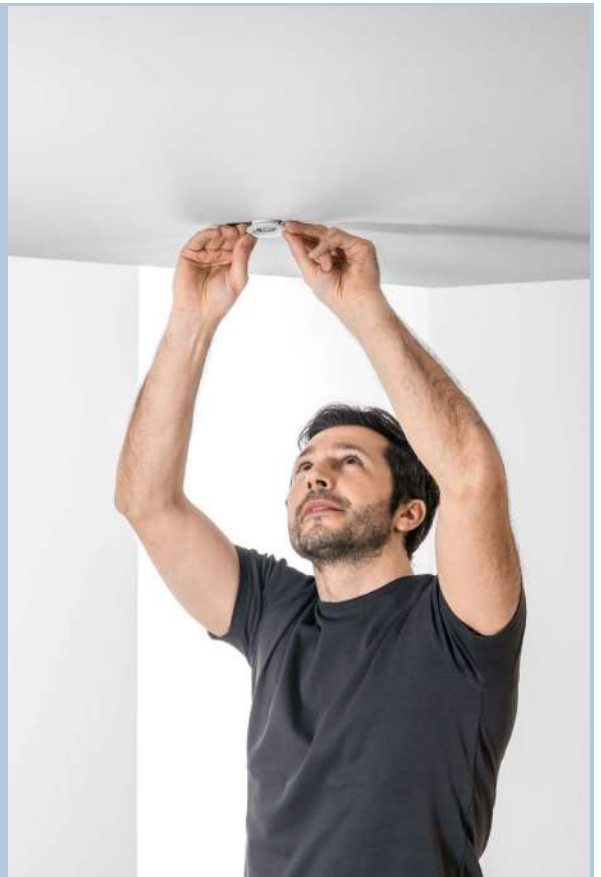
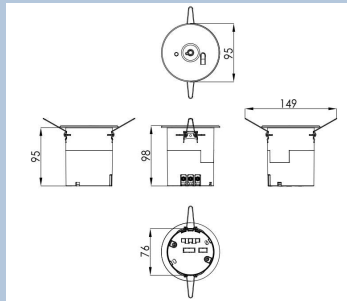

Surface
Mounted
Casing

Specification Data

Model: TTH731-ATS

Communication Protocol: Wi-Fi

Mode of Operation: Non-Maintained

Input Voltage: 240VAC 50 Hz

Power: 3W

Battery: Ni-Cd

Duration: 2-3 Hours

Lamp Source: White LED

Charging Period: 16-24 Hours (Full Charge)

Housing: PC+ABS Fire Retardant ABS Housing

Weight: 0.5Kg

Mounting: Ceiling recessed (optional casing for surface mounted)

Compliance: SS563:2010, SS IEC60598-2-22::;2016

Ingress Protection: IP30

Warranty: 3 Year

Ordering Guide

TTH731-ATS

SMC-Surface Mounted Casing



Note:

1. Due to continues product development, we reserves the right to change the specification without notice
Tel: +65-6291 0698 Fax: +65-6295 8440 E-mail: translite@pne.com.sg www: <http://www.pne.com.sg/industries/lighting.html>