



TBJ 300 SELF-CONTAINED EMERGENCY LUMINAIRE (LED)



Dimension : 355L x 75W x 120H

SPECIFICATION

Model	: TBJ 300
System Mode	: Non Maintained
Emergency Duration	: 2 hours
Lamp	: 18pcs SMD L.E.D. Strip
Battery	: 2.4V 1.6AH High temperature nickel cadmium battery
Recharge Period	: 16 fi 24 hours
Battery Protection	: Low Voltage cut off to prevent from over charging
Monitoring	: Green L.E.D. ¶ON¶ indicates charging Equipped with push test switch to simulate power failure
Input Voltage	: 240V 50Hz +/- 10%
Charger	: Constant current, Dual rate
Housing	: Injection molded fire retardant ABS housing & acrylic diffuser
Dimension	: 355L x 75W x 120H
Weight	: 0.8kg
Mounting	: Surface mounted direct to wall
Warranty	: 1 Year
Compliance	: SS 563 : 2010, SS 263 PART 2 : 1998

Note : Due to continuous development and improvement, our company reserves the right to change specifications without notice.

LUMINAIRE DATA SHEET

CUT-SHEET	QTY	LEGEND

LUMINAIRE DESCRIPTION: PNE TBJ300 BOX TYPE LED NON-MAINTAINED EMERGENCY LUMINAIRE C/W NI-CAD BATTERIES & WHITE LED

IMAGES/DIMENSIONS

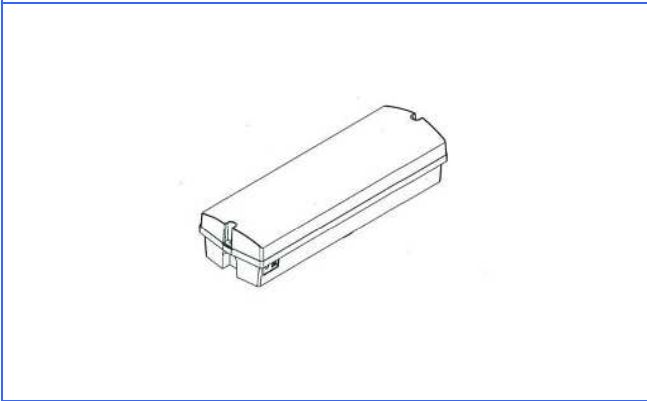
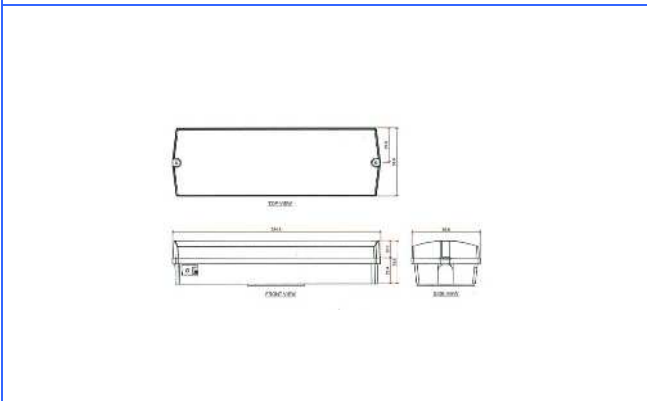

TECHNICAL SPECIFICATION

Brand / Model	: PNE / TBJ300
Lamp Source	: WHITE LED ARRAY
Avg Lamp Life	: 25,000 BURNING HOURS
Control Gear	: PNE300
Material	: INJECTION MOULDED FIRE RETARDANT ABS
Diffuser	: ACRYLIC DIFFUSER
IP Rating	: IP30

PNE TRANSLITE PTE LTD